

50MM TOW BALL HIGH SHOULDER

TOWBALL-50-HS

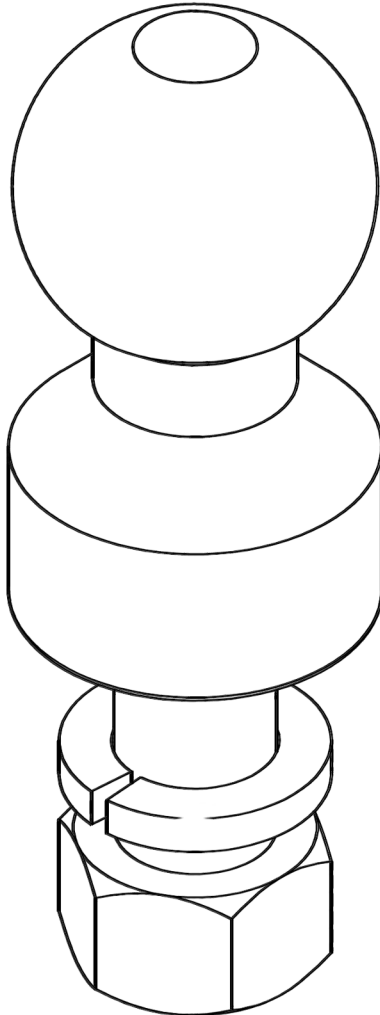

Packed by:
Date:



PRODUCT DESCRIPTION

The Couplemate™ TOWBALL-50-HS (“CM290-HT25-62”) is a 50mm tow ball with a high shoulder rated at 3500kg maximum ATM. The unit is Australian made, licensed with the Australia Made Campaign, and is manufactured in Brisbane (Couplemate™ HQ).

Each tow ball is supplied with a spring washer and nut. Spare parts may be purchased from Couplemate™ directly.

Spare Parts:

- Nut (7/8" x 14 TPI)
- Spring washer (7/8")

The component has a shoulder of 25mm, which is 13mm higher than standard 50mm balls.

The tow ball has a shank diameter of 22mm (7/8"). Please refer to the technical wireframe for further specifications.

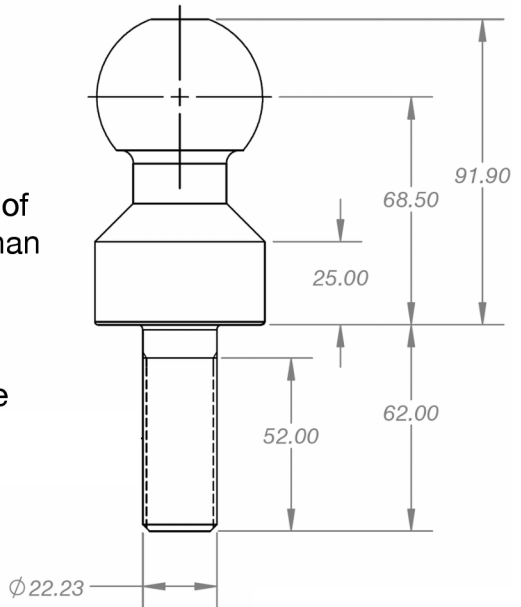

SAFETY & COMPLIANCE

Please ensure the tow vehicle, towbar receiver, and all other components are fit for application prior to use.

- **Maximum ATM:** 3500kg
- **Surface Finish:** Chrome
- **Torque Setting:** 368Nm
- **Material:** 4140

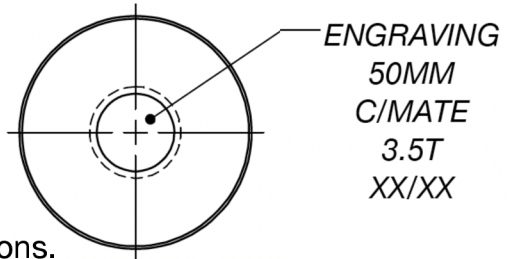

The towball is rated to 3500kg maximum ATM towing applications.

SAFETY & COMPLIANCE (CONT.)

The TOWBALL-50-HS was engineered, manufactured, and tested in strict accordance with AS 4177 and ADR 62/02 (Mechanical Connections between Vehicles). The tow ball is suitable for applications up to a maximum ATM of 3500kg.



Scan the QR code to view a sample of the component testing procedure.

YouTube Direct Link

<https://www.youtube.com/watch?v=AL7y4c5H96g>

CONTACT COUPLEMATE™

Brisbane Headquarters:

136 Glenora Street, Wynnum
Queensland 4178
Australia

Office Phone

+61 7 3348 3822

General Email

sales@couplemate.com.au

OUR CARE, YOUR WARRANTY

Our goods come with guarantees that cannot be excluded under the Australian Consumer Law. You are entitled to a replacement or refund for a major failure and compensation for any other reasonably foreseeable loss or damage. You are also entitled to have the goods repaired or replaced if the goods fail to be of acceptable quality and the failure does not amount to a major failure.

Couplemate™ is a manufacturer and vendor of high-quality towing, trailer, and caravan components. Couplemate™ Core Goods and Custom Work are guaranteed to be free of defects for the service life of the product when used as intended, as warranted under Couplemate™ Warranty Policy (“Our Care, Your Warranty”). Warranties are in addition to your consumer guarantee rights under the Australian Consumer Law.

Continued next page.

In the event a product be believed to be defective, cease use immediately and lodge a Warranty Claim at: www.couplemate.com.au/warranty/submit-claim.

Couplemate™ requires the Claim Form to be filled in its entirety and to be submitted by the Customer with photos of the defective Goods (including a photo of the trailer VIN plate). Completed forms are to be emailed to: sales@couplemate.com.au.

The completed Claim Form will be forwarded to multiple Couplemate™ departments (Engineering, Manufacturing, Management, Procurement) to investigate the issue and as such the Customer may be requested to provide additional information and photos.

Couplemate™ aims to review Warranty Claims within 14 business days of submission and will notify the Customer that the claim has been received. This time frame is subject to change, so Customers requiring urgent parts are recommended to place an order via phone: 07 3348 3822.

Couplemate™ reserves the right to inspect and assess Goods believed to be defective. In the event that a visual inspection is required, the component must be returned to: 136 Glenora Street, Wynnum 4178 Queensland, Australia.

Whereby Goods can be posted or easily returned, it is the Customer's responsibility to return the Goods to Couplemate™ for inspection. Customers are to retain a copy of receipts for transportation/postage costs. Whereby Goods cannot be posted or easily returned, Couplemate™ can organise and pay for collection/transportation of the Goods for inspection. Prior to collection, Couplemate™ will issue the Customer an estimated cost.

If a fault is found, Couplemate™ will issue a remedy under the ACL as well as reimburse the Customer for any reasonable return post costs. If a fault is not found, Couplemate™ will be unable to provide a remedy and, where applicable, may charge for transportation and reasonable costs as disclosed. Couplemate™ can return inspected Goods at the Customer's expense (estimated costs will be provided prior to requesting a visual inspection).

Warranties are non-transferrable and Couplemate™ requires satisfactory proof of purchase prior to issuing a remedy.

Couplemate™ will not provide a remedy wherein Goods are subject to misuse, abuse, neglect, or otherwise abnormal use and the same applies to fatigued Goods (i.e. Goods beyond service life), Goods with Expected Wear, or faults arising from improper installation. Removal, breakdown, or part thereof, on surface coatings constitutes Expected Wear and is not covered by Couplemate™ warranty.

It remains the full responsibility and liability of the Customer, or their chosen installer, to ensure proper installation and compliance with all relevant standards, guidelines, legislation, and governing bodies.

Couplemate™ shall not be held responsible nor liable for components, spare parts, Custom Work, or other Goods supplied to the Customer that are misused, abused, neglected, or otherwise abnormally used and/or installed resulting in a breach of legislation or regulation on any vehicle, powered or unpowered.